

# Main

## Main Proprietà

### Generale

Nome	Main	Numero	1
Tipo	OB.ProgramCycle	Linguaggio	KOP
<b>Informazioni</b>			
Titolo	"Main Program Sweep (Cycle)"	Autore	
Commento		Famiglia	
Versione	0.1	ID utente	

Nome	Tipo di dati	Offset
Temp		

### Segmento 1: Memoria Sicurezza

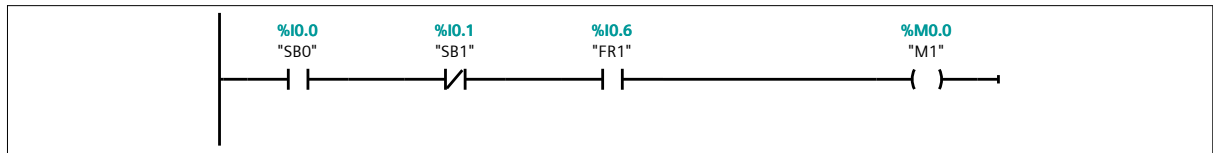

### Segmento 2: Ramo Relè per A+

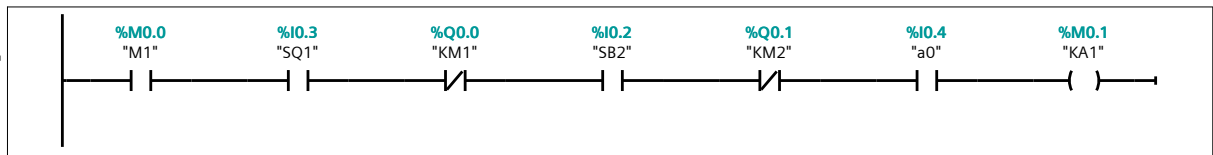

### Segmento 3: Ramo Relè A-

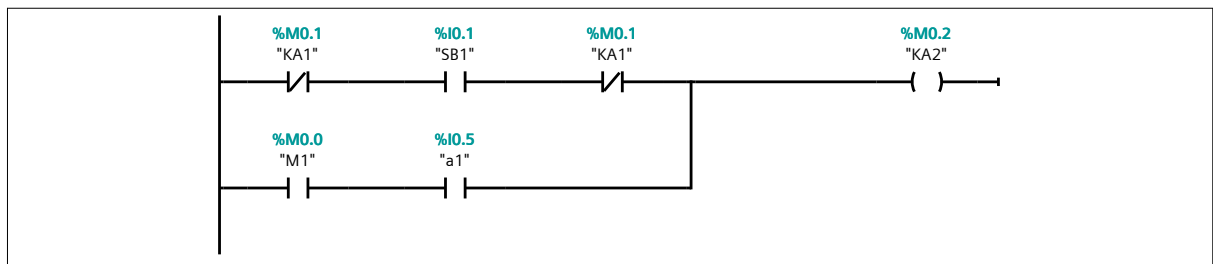

### Segmento 4: Marcia oraria M1 + temporizzatore T1

Owner	Project name Impianto Forno-Pneumatico		Date 10/04/2015
	Project Path C:\Pattuelli 2014\Impianto Forno-Pneumatico		
Operator	Location		
Designed By	Description 1st		
Checked By	Description 2nd	Language it-IT	
Approved By	1st View	Version	Sheet 1 - 1

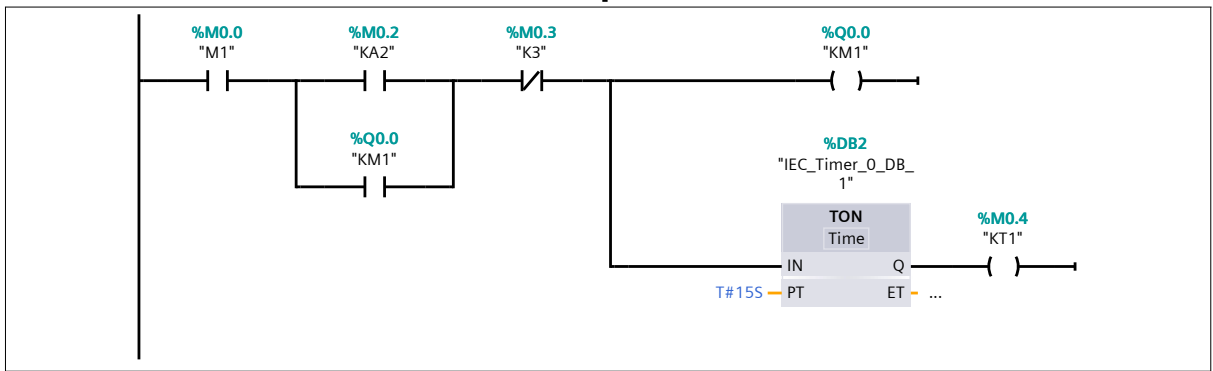

Segmento 5: Ramo Relè ausiliario + Temporizzatore T2

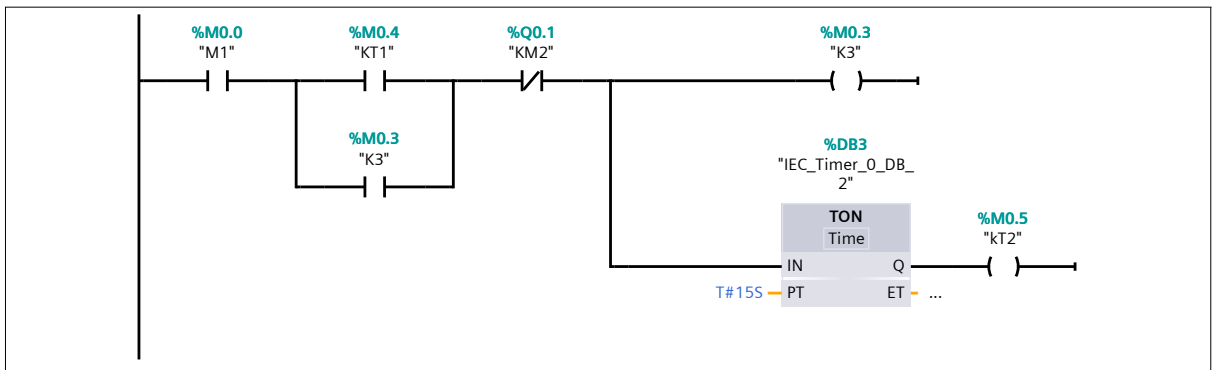

Segmento 6: Marcia antioraria M1

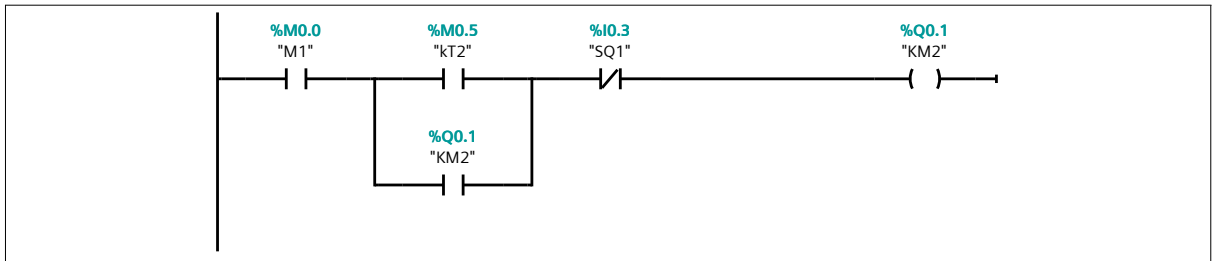

Segmento 7: Lampada marcia M1

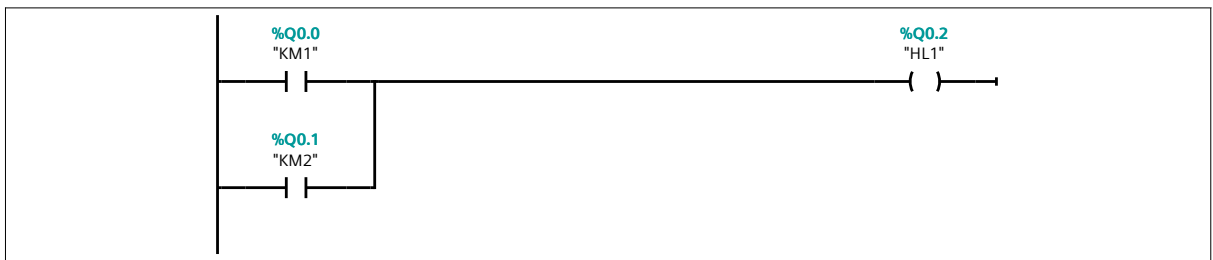

Owner	Project name Impianto Forno-Pneumatico		Date 10/04/2015
	Project Path C:\Pattuelli 2014\Impianto Forno-Pneumatico		
Operator	Location		
Designed By	Description 1st		
Checked By	Description 2nd	Language it-IT	
Approved By	1st View	Version	Sheet 1 - 2

1

2

3

4

A

### Segmento 8: Lampada presenza rete

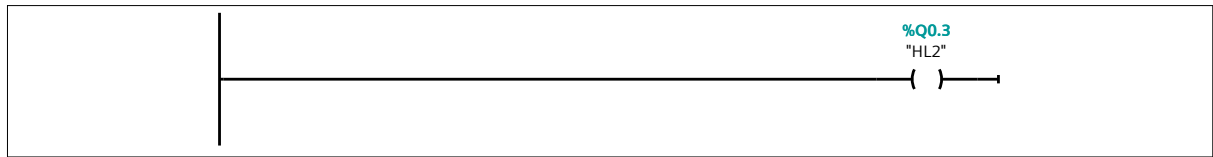

B

### Segmento 9: Lampada guasto termico

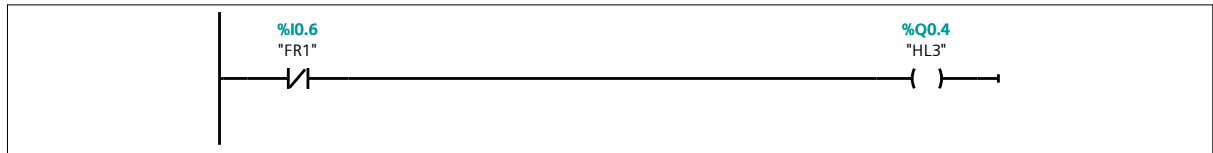

C

### Segmento 10: Bobina uscita pistone

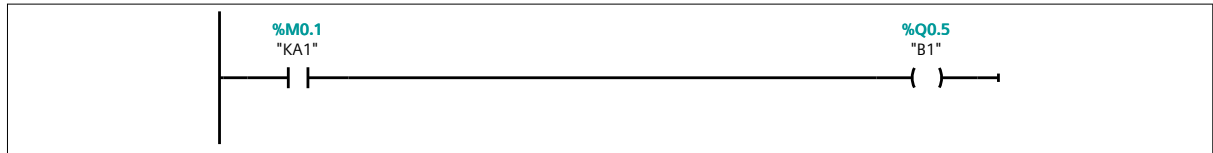

D

### Segmento 11: Bobina rientro pistone

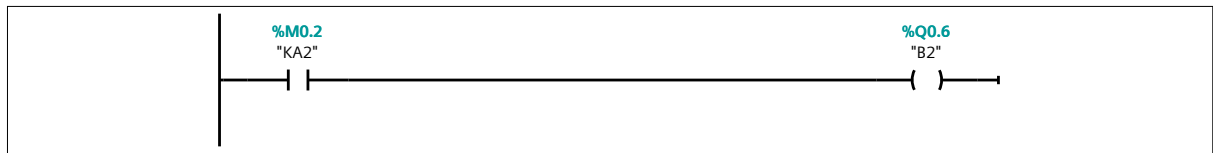

E

F

Owner	Project name	Impianto Forno-Pneumatico	Date	10/04/2015
	Operator	Project Path C:\Pattueli 2014\Impianto Forno-Pneumatico		
Designed By	Location			
Checked By	Description 1st	Language		
Approved By	Description 2nd	it-IT	Version	Sheet
	1st View			1 - 3